

1 Scope

This European Standard specifies a marking

- of electrical and electronic equipment in accordance with Article 11(2) of Directive 2002/96/EC (WEEE);

NOTE This is in addition to the marking requirement in Article 10(3) of this Directive which requires producers to mark electrical and electronic equipment put on the market after 13 August 2005 with a 'crossed-out wheeled bin' symbol.

- that applies to electrical and electronic equipment falling under Annex IA of Directive 2002/96/EC, provided the equipment concerned is not part of another type of equipment that does not fall within the scope of this Directive. Annex IB of Directive 2002/96/EC contains an indicative list of the products, which fall under the categories set out in Annex IA of this Directive;
- that serves to clearly identify the producer of the equipment and that the equipment has been put on the market after 13 August 2005.

The definition of a technical carrier medium for identifying the producer, such as a barcode, electronic data medium or microchip, is not covered by this standard.

2 Normative references

The following referenced documents are indispensable for the application of this document. For dated references, only the edition cited applies. For undated references, the latest edition of the referenced document (including any amendments) applies.

EN 28601:1992, Data elements and interchange formats – Information interchange – Representation of dates and times

EN 61429:1996/A11:1998, Marking of secondary cells and batteries with the international recycling symbol ISO 7000-1135 and indications regarding directives 93/86/EEC and 91/157/EEC

3 Definitions

For the purposes of this document, the following terms and definitions apply.

3.1

electrical and electronic equipment

equipment which is dependent on electric currents or electro-magnetic fields in order to work properly and equipment for the generation, transfer and measurement of such currents and fields falling under the categories set out in Annex IA of Directive 2002/96/EC and designed for use with a voltage rating not exceeding 1 000 V for alternating current and 1 500 V for direct current

3.2

producer

any person who, irrespective of the selling technique used, including by means of distance communication in accordance with Directive 97/7/EC:

- a) manufactures and sells electrical and electronic equipment under his own brand; or
- b) resells under his own brand equipment produced by other suppliers, a reseller not being regarded as the 'producer' if the brand of the producer appears on the equipment, as provided for in point a), or;
- c) imports or exports electrical or electronic equipment on a professional basis into a Member State

4 Marking

4.1 Requirements of marking

In order to identify a) the producer and b) the equipment put on the market after 13 August 2005, the following markings shall be applied on the product:

- a) a unique identification of the producer. This can take the form of a brand name, trademark, company registration number or other suitable means to identify the producer. Whichever option is chosen this shall be recorded in the member state's register of producers in accordance with Article 12(1) of Directive 2002/96/EC (WEEE);
- b) put on the market after 13 August 2005 shall be identified by either
 - 1) the date of manufacture/put on the market, in un-coded text in accordance with EN 28601 or other coded text, for which the code shall be made available for treatment facilities, or
 - 2) marking as shown in Figure 1 being an additional mark used in conjunction with the crossed-out wheeled bin in accordance with Annex IV of Directive 2002/96/EC already required under Article 10(3) of this Directive;

NOTE This does not exclude the use of both options at the same time.

The marking shall be accessible, durable, legible and indelible.

4.2 Design of the marking

The additional marking referred to in 4.1 b) 2) shall consist of a solid bar, the height of which equals h and the width of which equals $1,2 a$. The height (h) of the bar shall be the greater of $0,3 a$ or 1 mm . The bar shall only be used in conjunction with the crossed-out wheeled bin. The bar shall not contain any text or any kind of additional information.

The dimensional relationship shown in Figure 1 shall be maintained.

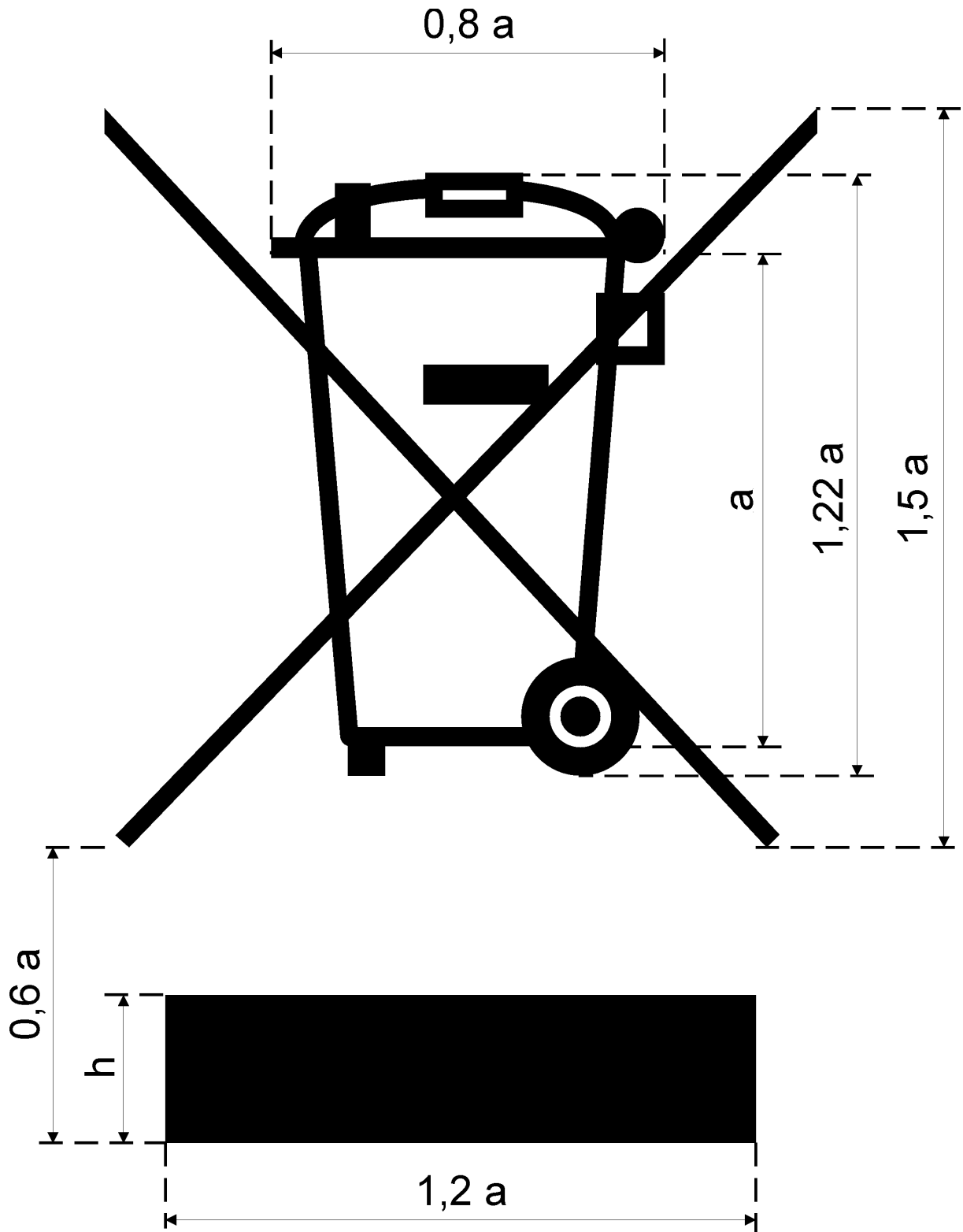

Figure 1 – Marking of electrical and electronic equipment as required by 4.1 b) 2)

NOTE 1 The symbol of the crossed out wheeled bin and the dimensional relationship are the same as required for batteries and defined in Figure 2 of EN 61429/A11.

When using the marking in Figure 1 modifications caused by production limitations and variations (e.g. modifying of line thickness, rounding of corners, matching of lines) are permitted provided the visual appearance is maintained.

In the absence of relevant product standards or if the relevant product standard does not include marking durability requirements, the following shall apply:

Compliance is checked by inspection and by rubbing by hand for 15 s with a piece of cloth soaked with water and again for 15 s with a piece of cloth soaked with petroleum spirit.

After this test, the marking shall be legible, it shall not be easily possible to remove the marking. If used, marking plates or labels shall show no curling.

NOTE 2 The petroleum spirit to be used for the test is aliphatic solvent hexane having a maximum aromatics content 0,1 % by volume, a kauri-butanol value of 29, an initial boiling point of approximately 65 °C, a dry point of approximately 69 °C and a specific mass of approximately 0,7 kg/l. When using petroleum spirit appropriate environmental, health and safety measures should be applied.

4.3 Adaptation of the location of the marking

If size or other characteristics such as functionality of the product means that the marking cannot be applied on the product, the marking shall be

- on a flag on the fixed supply cord (if any), and
- in the operating instructions and warranty certificates included with the product, if supplied.

If none of the above applies then the marking shall be on the packaging.

In the above cases in this subclause, the marking shall comply with the requirements of 4.1, and where appropriate, those of 4.2.
